

REVISIONS			
REV	DESCRIPTION	DATE	APPROVAL
B	REVISE AND REDRAW	7-11-89	96073 KDB
C	ADD P/N 5VA-12050-0N TO TAB	7-28-89	98089 RJM
D	ADD P/N 5VA-12050-0P TO TAB	10-24-91	91030 JL
E	CHANGE PWB ASSY PART NO	7-21-94	46033 JL
F	REMOVE P/N 5VA-12050-0N FROM CHART	7-21-99	96531
G	CHANGE 5VA1205000 BASE MKG P/N	8-29-01	16542

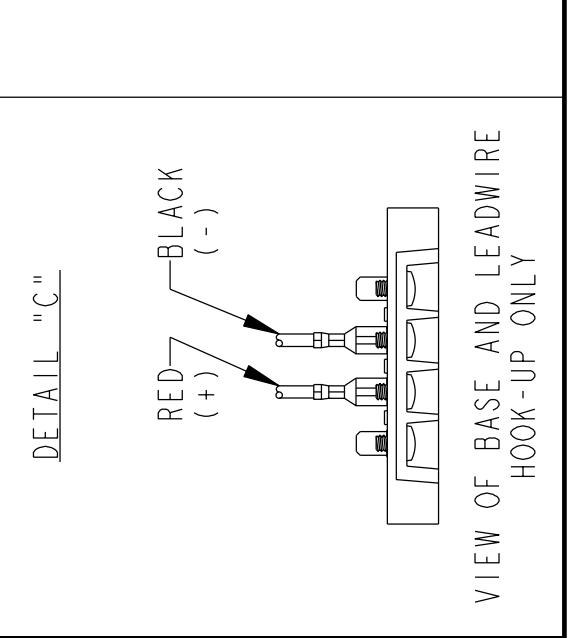
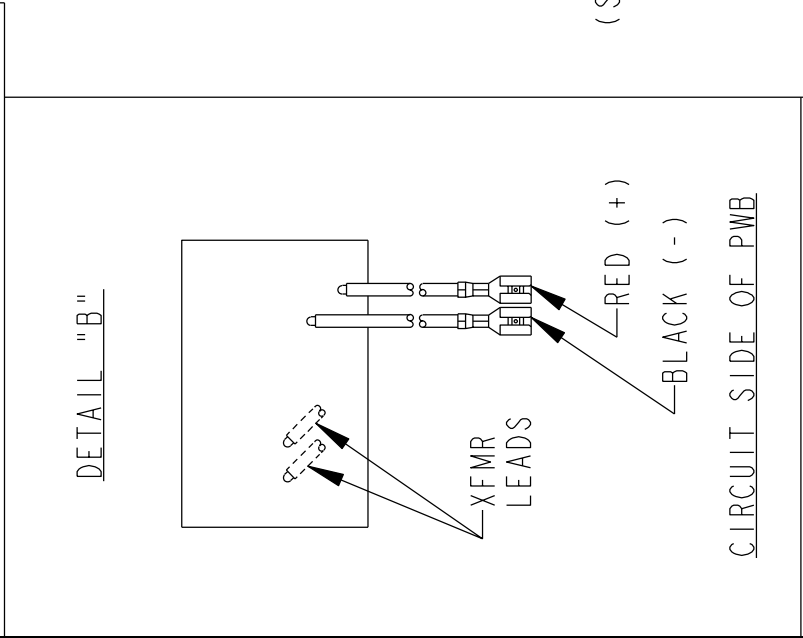
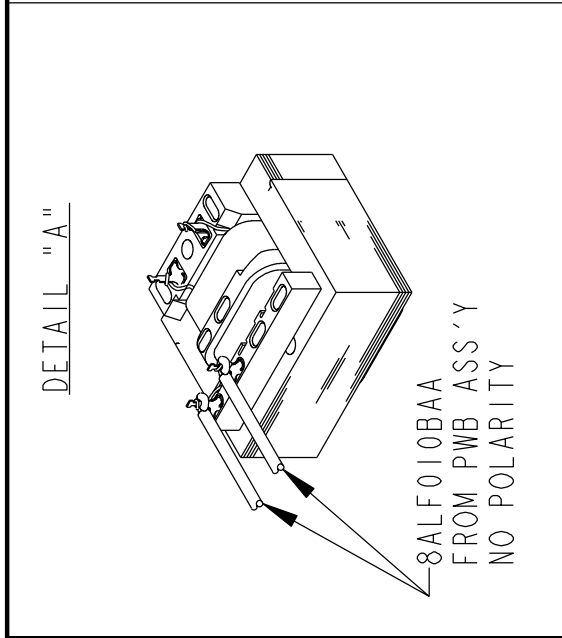
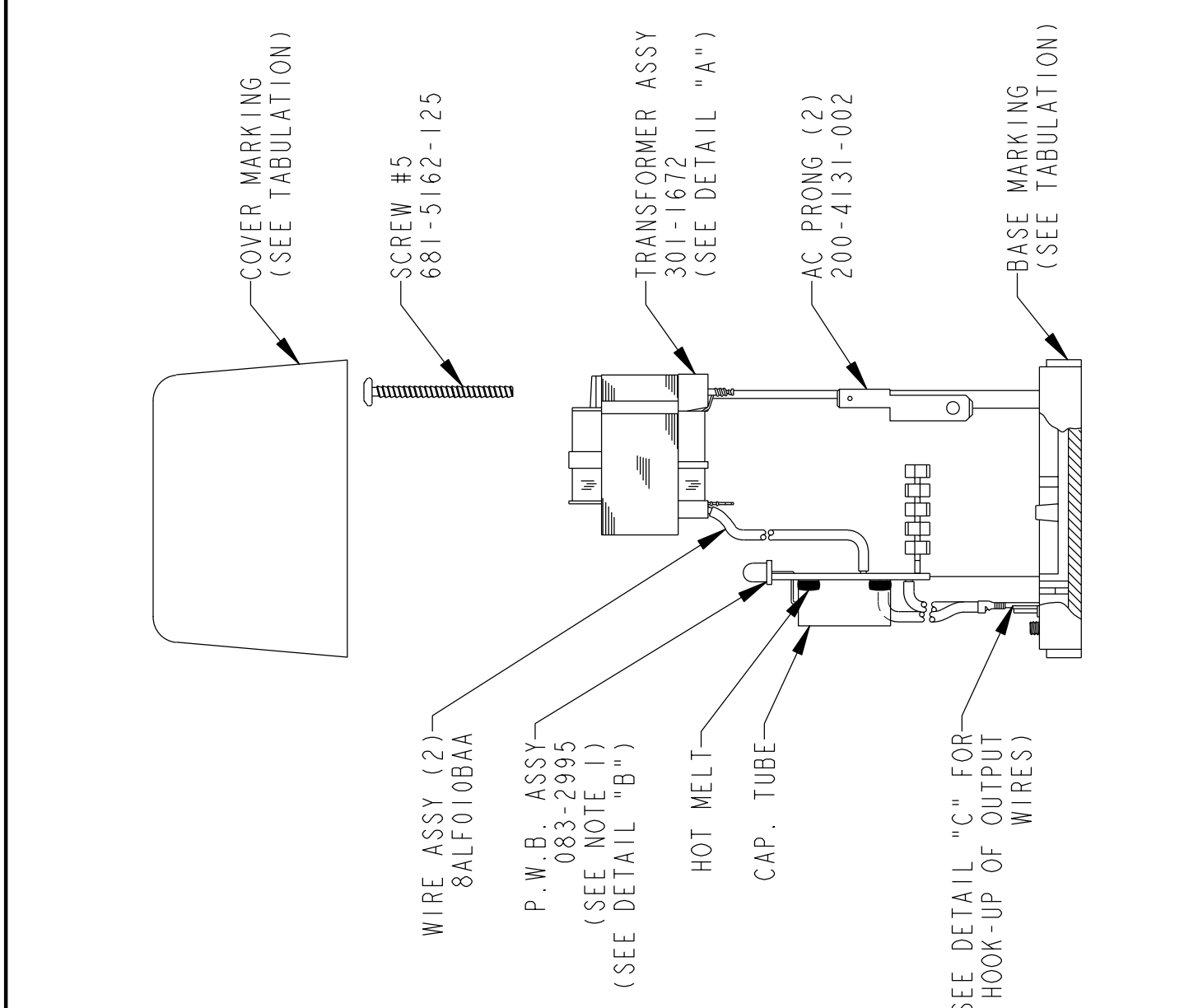

NOTES:

1. NOT ALL COMPONENTS SHOWN ON CIRCUIT BOARD ASSEMBLY FOR CLARITY.
2. HOT MELT PWB TO BASE AND CAP AND TUBE TO PWB.
3. HOT MELT POTS AFTER SETTING AT PRETEST.

TOLERANCES UNLESS NOTED OTHERWISE	SUPPLEMENTARY INFORMATION FIRST USED		BATTERY CHARGER FINAL ASSEMBLY	AULT AULT INCORPORATED MINNEAPOLIS, MINNESOTA
	DO NOT SCALE DRAWING	SCALE NONE		
.X ±.020	DRAWN BY M. HOVDE	29-Aug-01	SIZE B	DRAWING NO.
.XX ±.010	DESIGNER		5VA120500X	REV G
.XXX ±.005	AGENCY			
ANGLES ±.5°	ENGINEER			
	APPROVED RJM	4-22-85		SHEET 1 OF 1

UNIT	PART NO	REV	BASE ASSY	COVER MARKING
5VA-12050-00	J	170-2071	150-1368	150-1368
5VA-12050-02	J	150-1558	170-1974	170-1974
5VA-12050-07	H	150-1370	150-1368	150-1368
5VA-12050-0P	B	150-4580	150-4587	150-4587